

**Focus**

**Single lever basin mixer 100 without waste set**

Surfaces: **chrome** Art. no. : **31517003**



**Description**

**product features**

- ComfortZone 100
- flow rate: 5 l/min
- ceramic cartridge
- temperature limitation adjustable
- without waste set
- suitable for continuous flow water heaters
- connection dimension: DN15

**Technology**



WELS 5 Star/5 Litres per minute

**Product image**



**Scale drawing**

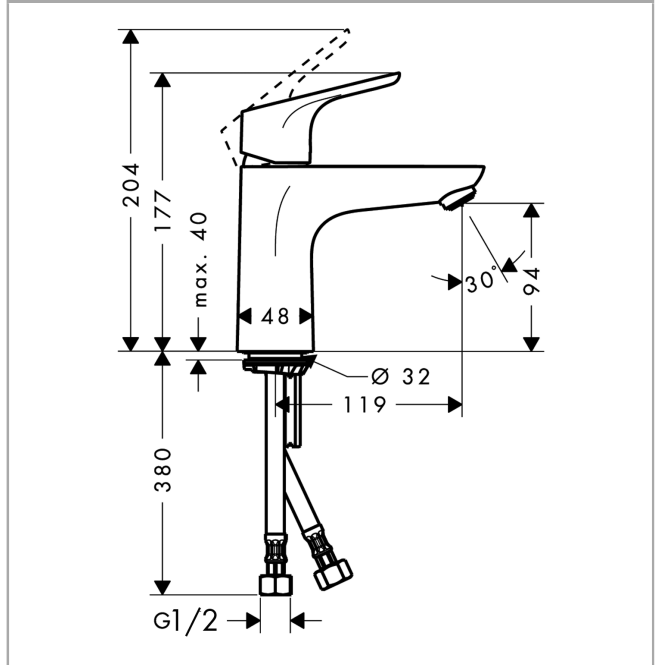

**Flowchart**

